

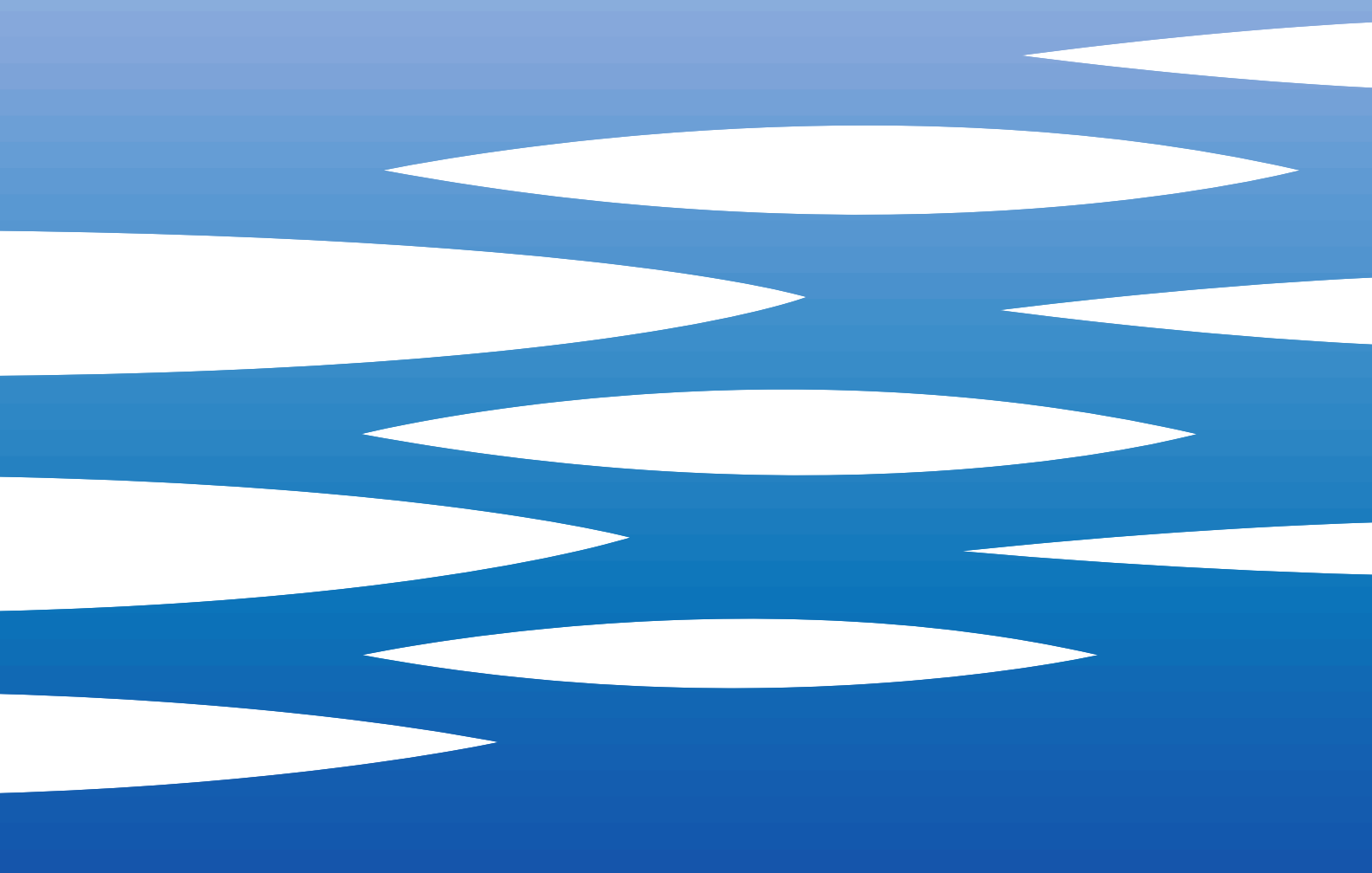

EBARA



	Page
- CONTENTS	100
- SPECIFICATIONS	200
SELECTION CHARTS	201
PERFORMANCE CHART 2CDX 70	202
PERFORMANCE CHART 2CDX 120	203
PERFORMANCE CHART 2CDX 200	204
- CONSTRUCTIONS	300
SECTIONAL VIEW	300
MECHANICAL SEAL	301
SINGLE PHASE DIAGRAM AND ELECTRIC CONNECTIONS	302
THREE PHASE DIAGRAM AND ELECTRIC CONNECTIONS	303
- DIMENSINS	400
PACKING AND WEIGHT	401
- TECHNICAL DATA	500

SPECIFICATIONS

50 Hz

PUMP		
Liquid Handled	Type of liquid	Clean water
	Max temperature [°C]	60 110 (2CDXH and 2CDXHS)
	Min temperature [°C]	-10
Maximum working pressure [MPa]		0.8
Construction	Impeller	Closed centrifugal type (Twin)
	Shaft seal type	Mechanical seal
	Bearing	Sealed ball bearing
Pipe Connection	Suction	G 1¼, G 1½ (2CDX200)
	Discharge	G 1
Material	Casing	AISI 304
	Impeller	AISI 304
	Casing cover	AISI 304
	Shaft seal	Ceramic/Carbon/NBR (2CDX) Ceramic/Carbon/FPM (2CDXH) SiC/SiC/FPM (2CDXHS)
	Shaft	AISI 304 (Wet extension)
	Bracket	Aluminium (up to 1.5 kW included) Cast iron (2.2 kW and above)
	Diffuser	AISI 304
Applicable standard of test		ISO 9906 – Annex A

MOTOR		
Type	Electric - TEFC	
	Single Phase	Three Phase
No. of Poles	2	
Rotation speed [min ⁻¹]	≈ 2800	
Insulation Class	Class F	
Protection degree	IP 55	
Power rating	[kW]	0.75 ÷ 1.5
	[HP]	1 ÷ 2
Frequency [Hz]	50	
Voltage [V]	230 ±10%	230/400 ±10%
Capacitor	Built in	-
Over load protection	Built in	Provided by the user
Casing material	Aluminium	
Base material/motor support	Aluminium	
Dimensions of cable entry	PG 11, PG 13.5, PG 16 (see dimension page 400)	

SPECIFICATIONS

50 Hz

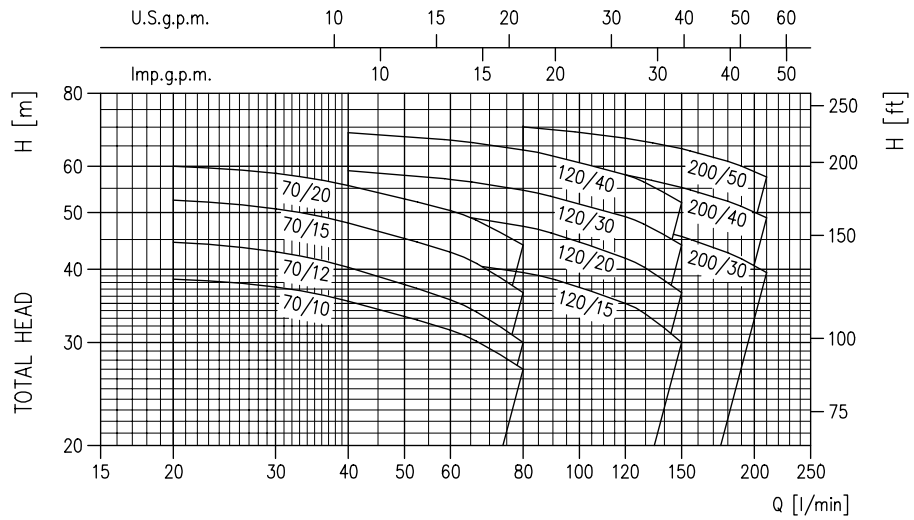

Type pumps		Power		Q=Capacity								
Single Phase	Three Phase	[kW]	[HP]	l/min	20	40	60	80	120	150	180	210
				m³/h	1.2	2.4	3.6	4.8	7.2	9.0	10.8	12.6
H=Total manometric head in meters												
2CDXM 70/10	2CDX 70/10	0.75	1	38.5	35.3	31.5	27	-	-	-	-	-
2CDXM 70/12	2CDX 70/12	0.9	1.2	44.5	40.3	35.5	30	-	-	-	-	-
2CDXM 70/15	2CDX 70/15	1.1	1.5	52.5	48	42.8	36.5	-	-	-	-	-
2CDXM 70/20	2CDX 70/20	1.5	2	60	55.6	50.4	44	-	-	-	-	-
2CDXM 120/15	2CDX 120/15	1.1	1.5	-	42	41	39.5	35	30	-	-	-
2CDXM 120/20	2CDX 120/20	1.5	2	-	51.5	49.5	47.4	41.8	36.5	-	-	-
-	2CDX 120/30	2.2	3	-	59	57	54.6	49.2	44	-	-	-
-	2CDX 120/40	3	4	-	68.5	66.5	64	58	52	-	-	-
-	2CDX 200/30	2.2	3	-	-	52	50.8	48.1	45.5	42.7	39.5	-
-	2CDX 200/40	3	4	-	-	62.5	61.1	58	55.2	52.3	49	-
-	2CDX 200/50	3.7	5.5	-	-	71.5	70.1	67	64.3	61.2	57.5	-

TYPE KEY:

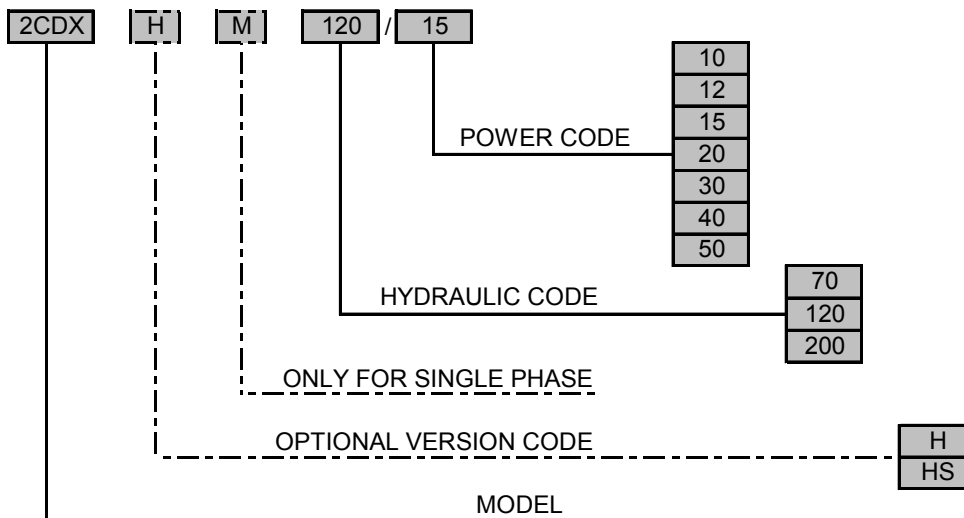

2CDX 70 PERFORMANCE CURVES

50 Hz

2CDX 70/10 (0.75 kW) Impeller diameter = 132/132
 2CDX 70/12 (0.90 kW) Impeller diameter = 153/132
 2CDX 70/15 (1.10 kW) Impeller diameter = 153/153
 2CDX 70/20 (1.50 kW) Impeller diameter = 153/176

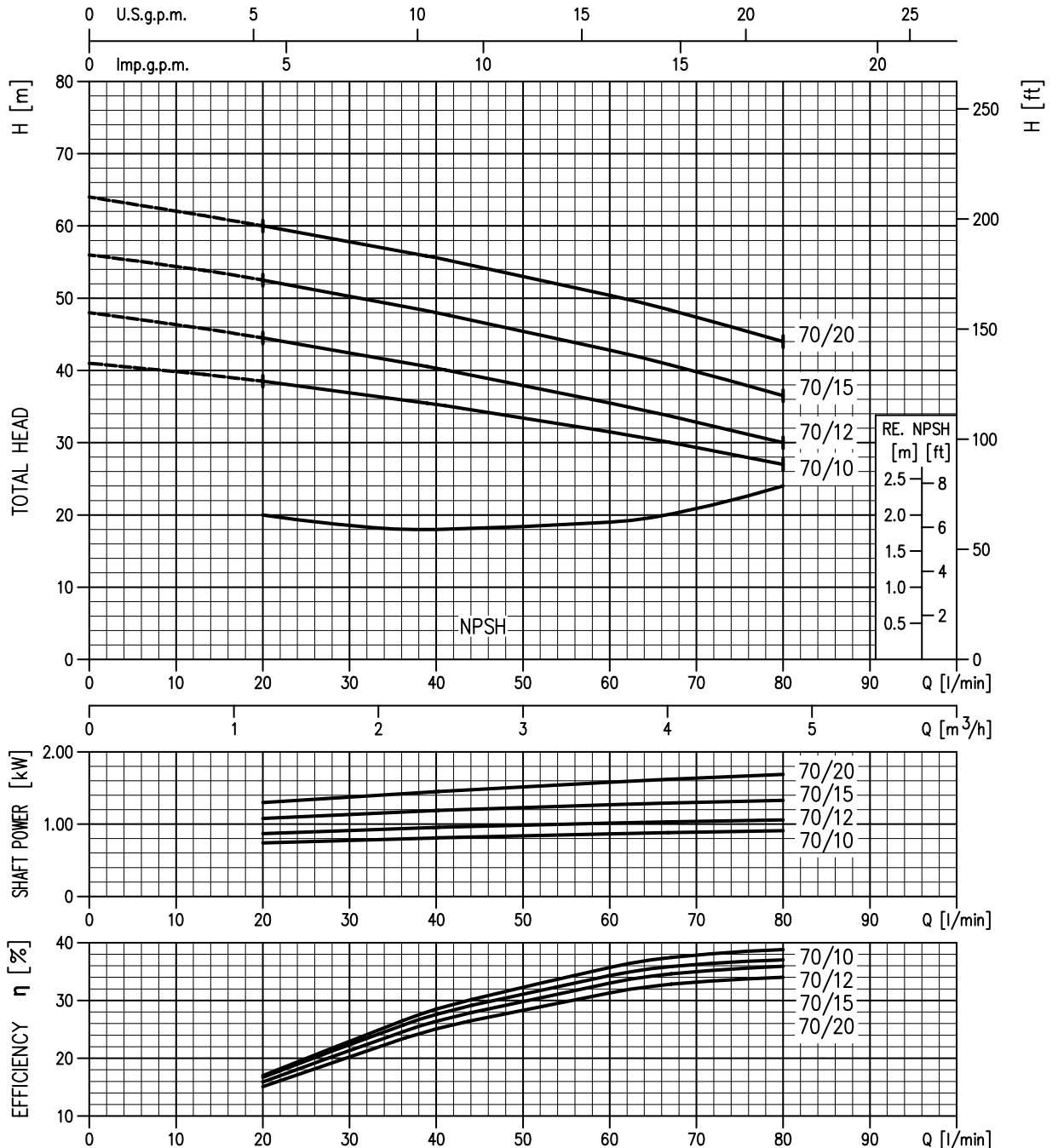

Rotation speed: $\approx 2800 \text{ min}^{-1}$
 Test fluid: clean water at 20°C
 Applicable standard of test: ISO 9906 – Annex A

2CDX 120 PERFORMANCE CURVES

50 Hz

2CDX 120/15 (1.10 kW) Impeller diameter = 132/132
 2CDX 120/20 (1.50 kW) Impeller diameter = 157/132
 2CDX 120/30 (2.20 kW) Impeller diameter = 157/157
 2CDX 120/40 (3.00 kW) Impeller diameter = 176/157

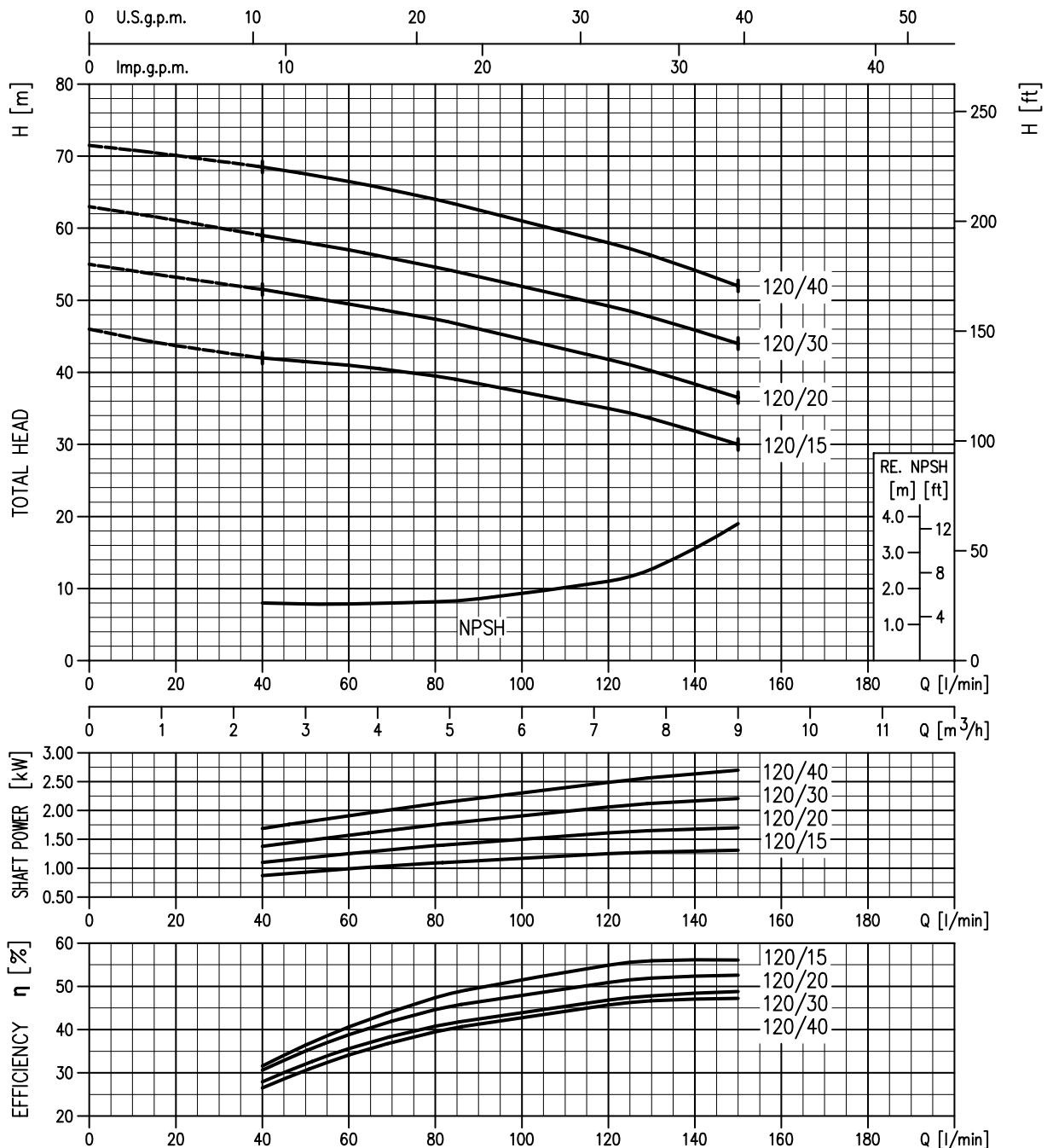

Rotation speed: $\approx 2800 \text{ min}^{-1}$
 Test fluid: clean water at 20°C
 Applicable standard of test: ISO 9906 – Annex A

2CDX 200 PERFORMANCE CURVES

50 Hz

2CDX 200/30 (2.20 kW) Impeller diameter = 157/132
 2CDX 200/40 (3.00 kW) Impeller diameter = 157/157
 2CDX 200/50 (3.70 kW) Impeller diameter = 176/157

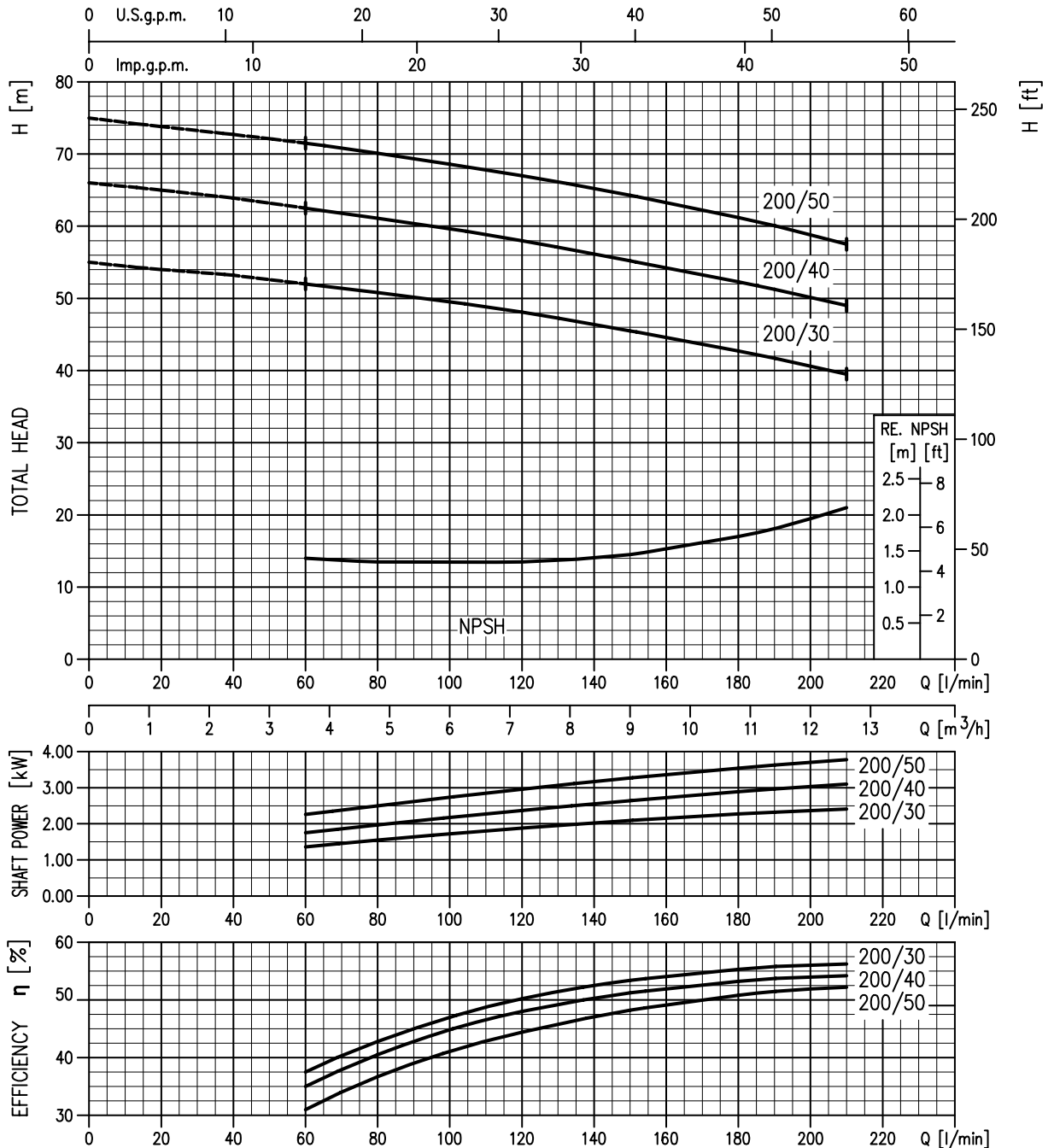

Rotation speed: $\approx 2800 \text{ min}^{-1}$
 Test fluid: clean water at 20°C
 Applicable standard of test: ISO 9906 – Annex A

SECTIONAL VIEW

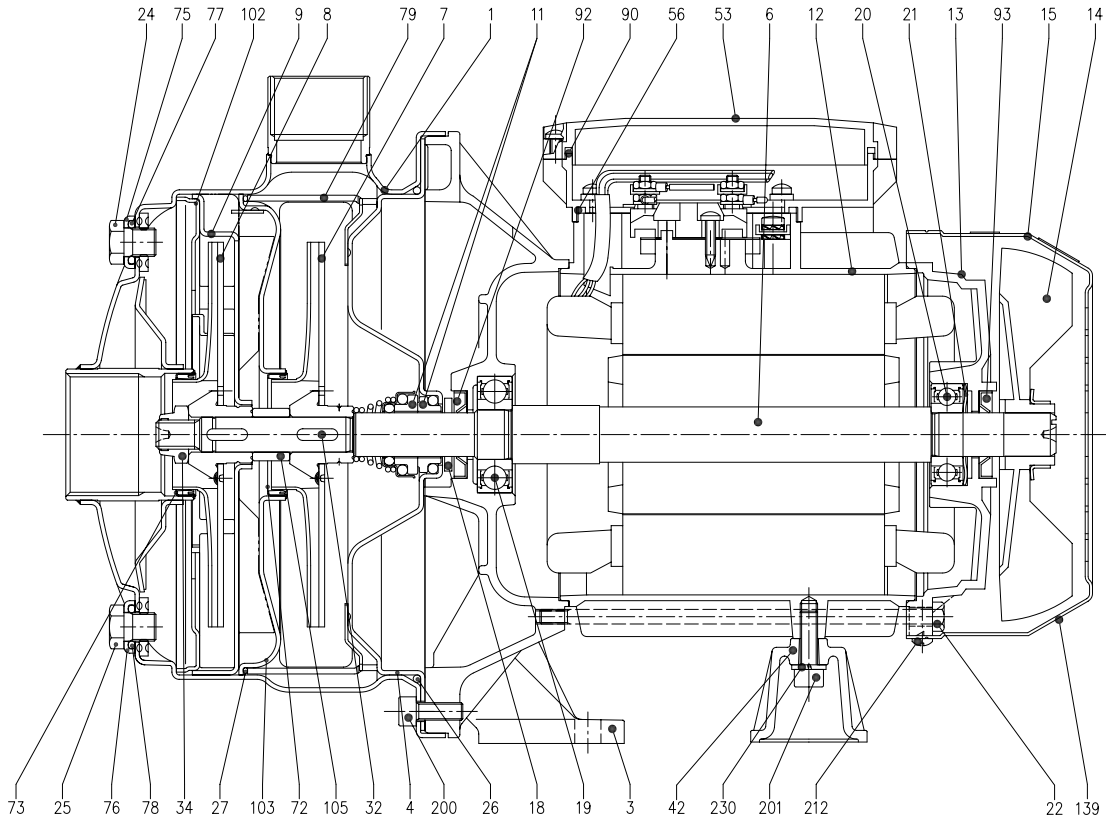

N°	PART NAME	MATERIAL	Q.TY	N°	PART NAME	MATERIAL	Q.TY
1	Casing	AISI 304	1	26	O-ring [3]	NBR	1
3	Motor bracket	Aluminium (up to 1.5 kW included) Cast iron (for 2.2 kW and above)	1	27	O-ring [3]	NBR	1
4	Casing cover	AISI 304	1	32	Key	AISI 304	2
6	Shaft with rotor	AISI 304 (Part in contact with liquid)	1	34	Impeller nut	AISI 304	1
7	Impeller	AISI 304	1	42	Motor support	Aluminium	1
8	Impeller	AISI 304	1	52	Terminal box [1]	Polypropilene	1
9	Diffuser	AISI 304	1	53	Terminal box cover [1]	Polypropilene	1
11	Mechanical seal [3]	Ceramic/Carbon/NBR	1	56	Box gasket	NBR	1
12	Motor frame with stator	-	1	72	Casing ring [3]	NBR	1
13	Motor cover	Aluminium	1	73	Casing ring [3]	NBR	1
14	Fan	Polypropilene	1	75	Washer	AISI 304	1
15	Fan cover	Fe P04 Zinked	1	76	Washer	AISI 304	1
16	Terminal box	-	1	77	O-ring [3]	NBR	1
17	Terminal box cover [2]	Aluminium	1	78	O-ring [3]	NBR	1
18	Splash ring	NBR	1	79	Space diffuser	AISI 304	1
19	Pump side ball bearing	-	1	90	Cover gasket [1]	NBR	1
20	Fan side ball bearing	-	1	92	Lip seal	-	1
21	Adjusting ring	Steel C70	1	93	Lip seal	-	1
22	Tie rod	Fe 42 Zinked	4	102	Suction cover	AISI 304	1
23	Capacitor [1]	-	1	103	Conveyor cover	AISI 304	1
24	Priming plug	AISI 303	1	105	Sleeve	AISI 304	1
25	Drain plug	AISI 303	1	110	Protector [1]	-	1
				200	Screw	Stainless steel A2 UNI7323	8

[1] Only for single phase
[2] Only for three phase

[3] FPM for 2CDXH and 2CDXHS

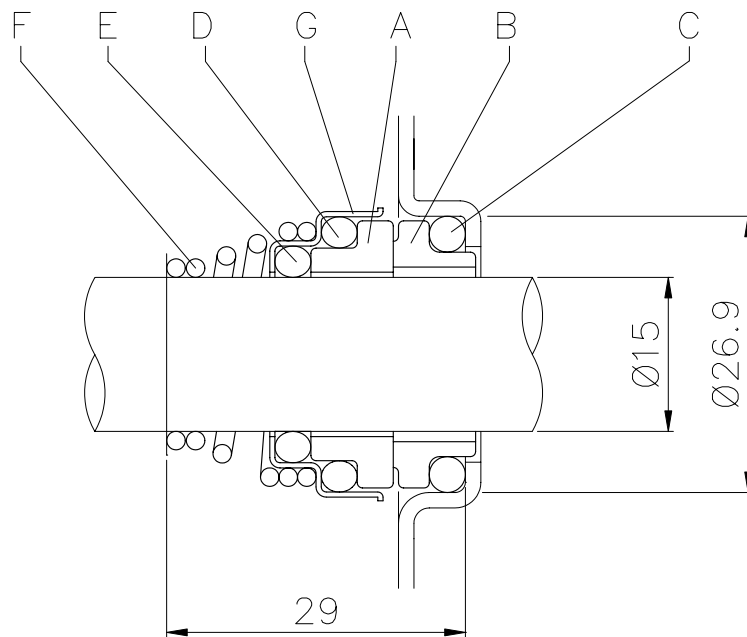

REF	PART NAME	MATERIAL		
		Standard version (2CDX)	Optional (2CDXH)	Optional (2CDXHS)
A	Rotary seal ring	Ceramic	Ceramic	Silicon carbide
B	Stationary seal ring	Carbon graphite	Carbon graphite	Silicon carbide
C	O Ring	NBR	FPM	FPM
D	O Ring	NBR	FPM	FPM
E	O Ring	NBR	FPM	FPM
F	Self driving spring	AISI 316	AISI 316	AISI 316
G	Frame	AISI 304	AISI 304	AISI 316

FOR MOTORS WITH LOCKED ROTOR CURRENT
UP TO 25 [A]
(INTERNAL MOTORPROTECTOR)

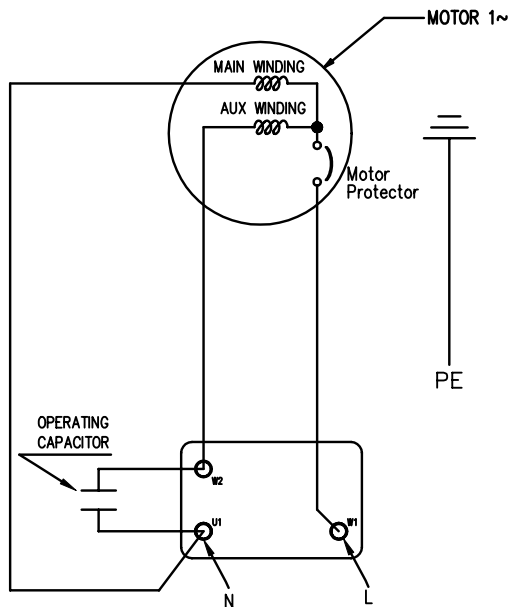

FOR MOTORS WITH LOCKED ROTOR CURRENT
OVER 25 [A]
(EXTERNAL MOTORPROTECTOR)

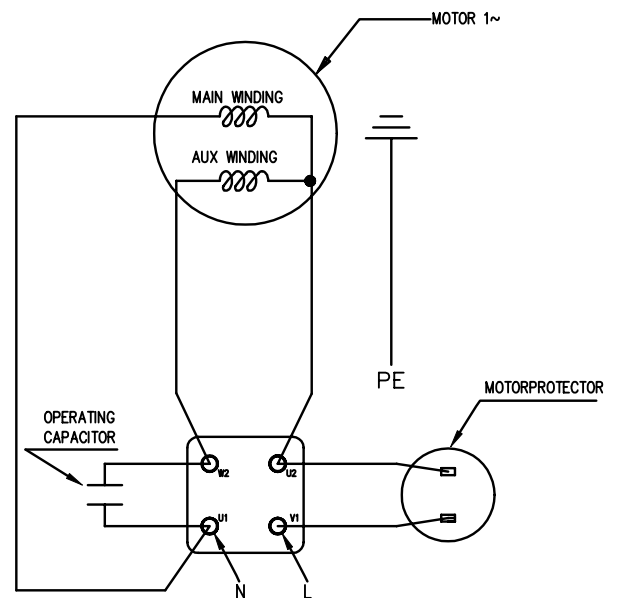

PUMP	MOTORPROTECTOR	
	INTERNAL	EXTERNAL
2CDXM 70/10	X	
2CDXM 70/12	X	
2CDXM 70/15		X
2CDXM 70/20		X
2CDXM 120/15		X
2CDXM 120/20		X

STAR CONNECTION

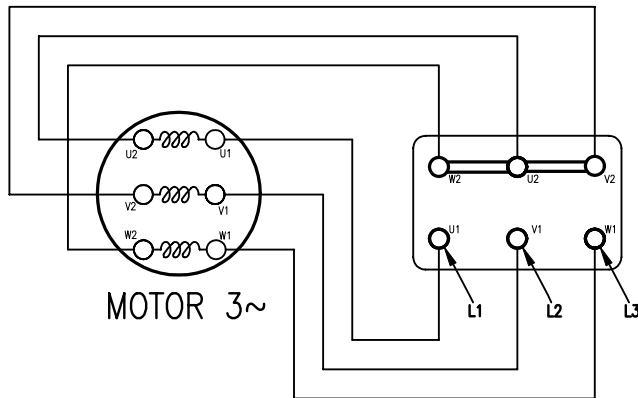

DELTA CONNECTION

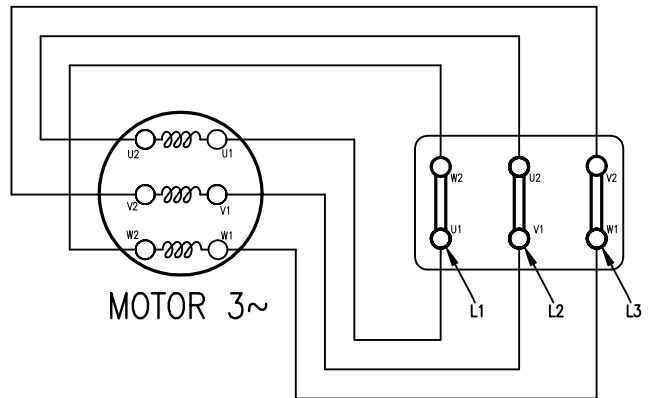

FOR MOTOR 4 kW AND BELOW

DELTA CONNECTION 230 V

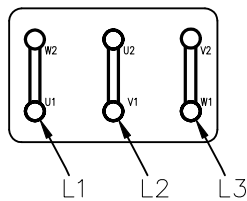

STAR CONNECTION 400 V

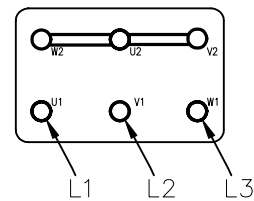

DIMENSIONS

50 Hz

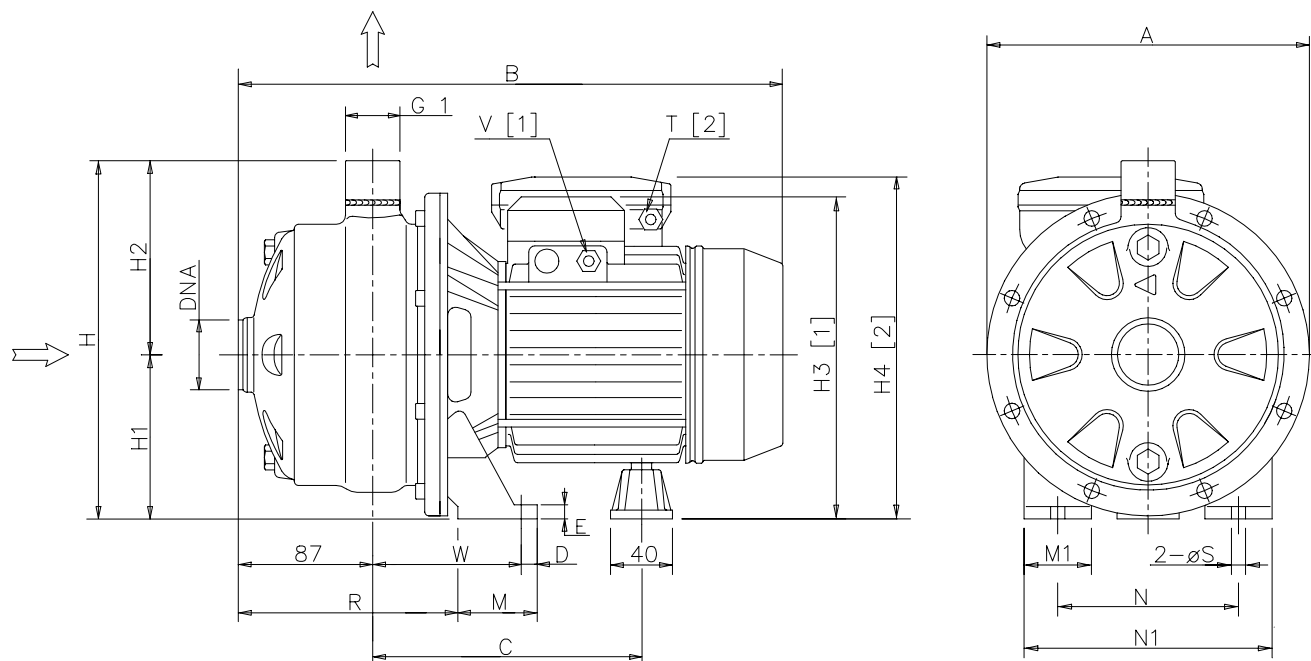

Pump type	Dimensions [mm]																				
	A	B	C	D	E	H	H1	H2	H3	H4	M	M1	N	N1	R	T	V	W	S	DNA	
2CDXM 2CDX																					
70/10	208	355	182	12.5	8	229	106	123	208	216	50	38	120	160	143	PG 11	PG 11	93	9	G1¼	
70/12	208	355	182	12.5	8	229	106	123	208	235	50	38	120	160	143	PG 13.5	PG 11	93	9	G1¼	
70/15	232	383	204	12.5	8	250	118	132	237	249	55	40	140	180	142	PG 13.5	PG 11	95	9	G1¼	
70/20	232	383	204	12.5	8	250	118	132	237	249	55	40	140	180	142	PG 13.5	PG 11	95	9	G1¼	
120/15	208	383	204	12.5	8	229	106	123	225	237	55	40	140	180	142	PG 13.5	PG 11	95	9	G1¼	
120/20	208	383	204	12.5	8	229	106	123	225	237	55	40	140	180	142	PG 13.5	PG 11	95	9	G1¼	
120/30	232	397	205 / 216	12.5	8	250	118	132	244	-	65	40	140	180	144	-	PG 13.5	109	9	G1¼	
120/40	232	422	230 / 241	12.5	10	250	118	132	244	-	65	40	140	180	144	-	PG 13.5	109	9	G1¼	
200/30	208	419	227 / 238	12.5	10	229	106	123	232	-	65	40	140	180	144	-	PG 13.5	109	9	G1½	
200/40	232	422	230 / 241	12.5	10	250	118	132	244	-	65	40	140	180	144	-	PG 13.5	109	9	G1½	
200/50	232	435	232	16	13	250	118	132	257	-	68	50	160	210	144	-	PG 16	109	12	G1½	

- [1] Three phase
- [2] Single phase

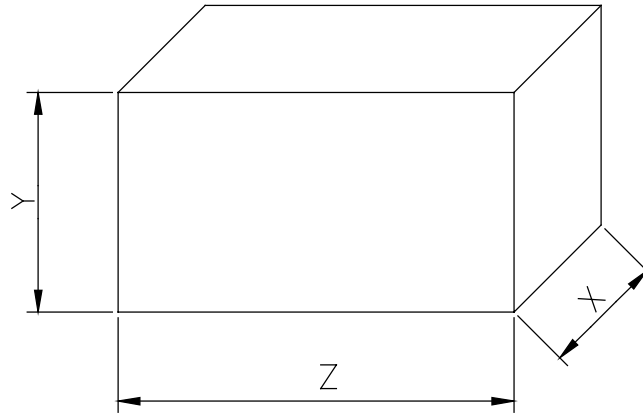

Type pumps		PACKING [mm]			WEIGHT [kg]	
Single Phase	Three Phase	X	Y	Z	Single Phase	Three Phase
2CDXM 70/10	2CDX 70/10	255	300	367	13.5	13.3
2CDXM 70/12	2CDX 70/12	255	300	367	14.2	13.8
2CDXM 70/15	2CDX 70/15	255	300	397	17.4	16.4
2CDXM 70/20	2CDX 70/20	255	300	397	18.6	18.2
2CDXM 120/15	2CDX 120/15	255	300	397	15.5	15.3
2CDXM 120/20	2CDX 120/20	247	300	397	18	16.9
-	2CDX 120/30	252	300	457	-	23.2
-	2CDX 120/40	252	300	457	-	26.4
-	2CDX 200/30	239	300	457	-	25
-	2CDX 200/40	239	300	457	-	25
-	2CDX 200/50	247	300	457	-	32.7

TECHNICAL DATA

50 Hz

Type pumps		kW	HP	Ball Bearing		Capacitor		Input in [kW]		Full load current in [A]		
Single Phase 230 V 50 Hz	Three Phase 230/400 V 50 Hz			Pump side	Fan side	Single Phase µF	Vc	Single Phase	Three Phase	Single Phase	Three Phase 230 V	400 V
2CDXM 70/10	2CDX 70/10	0,75	1	6203 ZZ	6202 ZZ	20	450	1,30	1,18	6,0	4,0	2,3
2CDXM 70/12	2CDX 70/12	0,9	1,2	6203 ZZ	6202 ZZ	31,5	450	1,50	1,50	7,0	5,0	2,9
2CDXM 70/15	2CDX 70/15	1,1	1,5	6204 ZZ	6203 ZZ	35	450	1,80	1,64	8,0	5,6	3,2
2CDXM 70/20	2CDX 70/20	1,5	2	6204 ZZ	6203 ZZ	40	450	2,30	2,20	9,9	7,0	4,0
2CDXM 120/15	2CDX 120/15	1,1	1,5	6204 ZZ	6203 ZZ	35	450	1,80	1,70	8,3	5,6	3,2
2CDXM 120/20	2CDX 120/20	1,5	2	6204 ZZ	6203 ZZ	40	450	2,35	2,20	10,2	7,0	4,0
-	2CDX 120/30	2,2	3	6305 ZZ	6205 ZZ	-	-	-	2,85	-	8,7	5,0
-	2CDX 120/40	3	4	6305 ZZ	6205 ZZ	-	-	-	3,50	-	10,8	6,2
-	2CDX 200/30	2,2	3	6205 ZZ	6205 ZZ	-	-	-	3,05	-	10,4	6,0
-	2CDX 200/40	3	4	6305 ZZ	6205 ZZ	-	-	-	3,85	-	11,4	6,6
-	2CDX 200/50	3,7	5	6206 ZZ	6205 ZZ	-	-	-	4,60	-	15,0	8,7

Type pumps		Locked rotor current		
Single Phase 230 V 50 Hz	Three Phase 230/400 V 50 Hz	Single Phase 230 V 50 Hz	Three Phase 230 V 400 V 50 Hz	
2CDXM 70/10	2CDX 70/10	22.7	24.1	13.9
2CDXM 70/12	2CDX 70/12	25.5	28.2	16.3
2CDXM 70/15	2CDX 70/15	39	29.4	17
2CDXM 70/20	2CDX 70/20	43	45	26
2CDXM 120/15	2CDX 120/15	39	29.4	17
2CDXM 120/20	2CDX 120/20	43	45	26
-	2CDX 120/30	-	58.9	34
-	2CDX 120/40	-	84.9	49
-	2CDX 200/30	-	84.9	49
-	2CDX 200/40	-	84.9	49
-	2CDX 200/50	-	132.7	76.6